

Panther Shadow

Low Cost Automated Labeling System

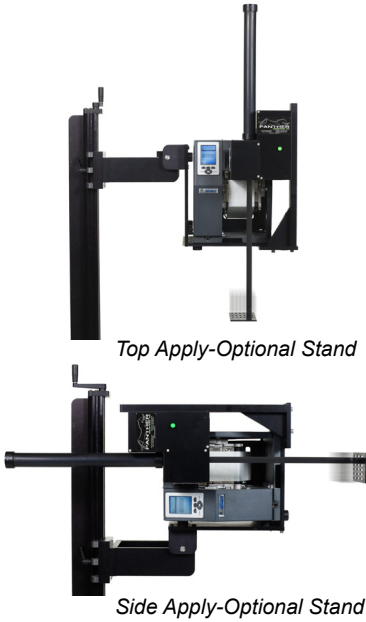

Top Apply-Shown in Table Top Mode

The Panther Shadow Print and Apply Labeling System is designed as an entry level system into "real-time" on demand labeling. The Shadow is the lowest cost print and apply system on the market. It is also the only low cost ELECTRIC print and apply system in the world.

The Shadow allows the user to print and apply a label in an instant. Unlike "loose-loop" systems, the label printed on the Shadow is immediately available for application. There are no labels queued up so the information on the label is accurate and real-time.

The Shadow is a great product for labeling in work cells. It is easily integrated with scale heads, barcode scanners, WMS and ERP systems. It is the easiest system to use with the built in Auto-Tamp feature. There are ZERO user adjustments outside of the printer settings.

The Shadow can be set up and working in literally minutes after removing it from its box. With the capability of simply setting the Shadow on a table and plugging it in, you can be applying labels in minutes.

The Shadow can also be placed on a stand and rolled up to a conveyor for top and side application of labels.

By adding RFID capabilities to the printer, the Shadow becomes the lowest cost, automated RFID labeling system available.

The Shadow accepts label sizes from 3" x 1" up to 4" x 6" right out of the box. The Shadow can also be configured for labels up to 8" Long.

With standard configurations, the Shadow is available the day you place your order.

ENGINEERED
to be the best

- Low Cost
- ELECTRIC-No Compressed Air
- 10" Stroke Tamp System
- No User Adjustments
- Table Top or Stand Mountable
- Serial, Parallel, USB, & Ethernet - STANDARD
- AC Power is the only utility you will need
- "Auto Tamp" for true variable stroke distances
- Table-Top or Stand Mountable
- Perfect for RFID applications

SPECS



MEDIA SIZES

8" O.D. Label Supply Roll
 Standard 3" Roll Core
 min label width: 1.00"
 max label width: 4.65" (4")
 max print width: 4.09" (4")
 max label length: 8.00" (Panther Spec)
 min label length: 1.00" (Panther Spec)
 print speed: up to 12 IPS (Printer Model Dependent)
 label sensing (TOF): gap, notch/hole, reflective eye-mark
 Ribbon Max Length: 600M
 Ribbon Width: 1.0" to 4.5" (4")
 Ribbon Wind: CSI and CSO

COMMUNICATIONS

Serial (RS-232), Parallel (IEEE-1284), USB, Ethernet (included)
 Wireless Ethernet 802.11g (optional)

GENERAL

10" Stroke (Peel/Home to Base +10")
 Auto-Tamp Product Contact Sensing
 Print Request Push Button
 Shipping Weight: 97 LBS

ENVIRONMENT

Operating Temp: 32°~100°F (0° to 38° C)
 Storage Temp: 0° to 140°F (-17° to 60° C)
 Humidity: 10~95% Non-Condensing
 Dust: Non-Conducting, Non-Corrosive

UTILITIES

Electrical: 115~240VAC VAC 50/60 Hz at 5A max.
 (No air required)

INCLUDING

Full Documentation on Included CD-ROM:
 Soft Copy of Panther Shadow Manual
 One Year Limited Warranty
 All Mounting Brackets, photoeyes, RTR

OPTIONS

Spare Parts Kit (PA-SPK-004)
 T-Base Stand Mounting Kit (PA-STAND-SH001)
 T-Base Stand with Locking Casters (PA-STAND-001)
 Palm Switch (PA-SH-SW1)
 Foot Switch (PA-SH-SW2)
 203, 300, 406, 600 DPI Resolutions
 Integrated RFID Kit
 Wireless Ethernet Module

CONFIGURATIONS

Table-Top
 Stand Mount-Side Apply
 Stand Mount-Top Apply

ENGINEERED
to be the best



DATAMAX®

All Dimensions are in inches.
 Please contact engineering for
 stand-mounted dimensions of the
 Panther Shadow System.

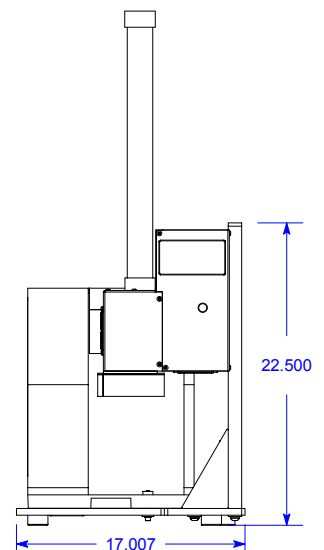
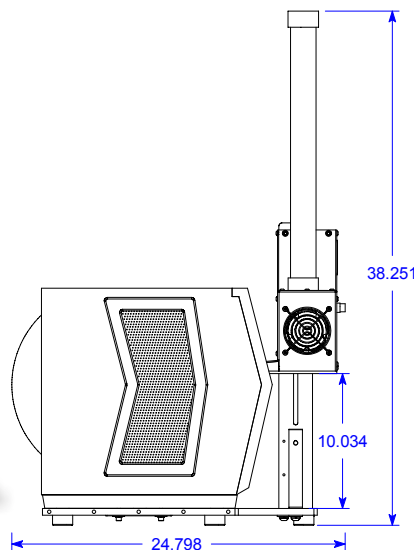
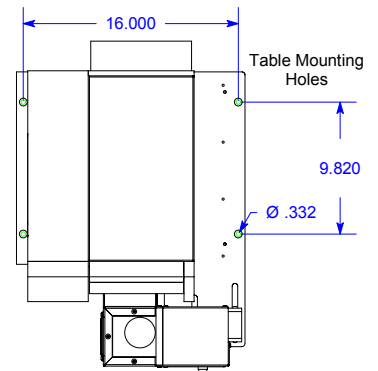

PANTHER INDUSTRIES, INC.

2703 S. Shoshone St. • Englewood, Colorado 80110
 303.703.9876 • 800.530.6018 • 720.283.9462 (fax)
www.print-n-apply.com

Panther Shadow - Ready to Run!